

How To Make A Shaper For Caprails by Roger Van De Walker

To put fancy edges on small pieces of wood, use a scratch stock. The shape of the edge is limited by your ability to find grinding wheels small enough and your imagination.

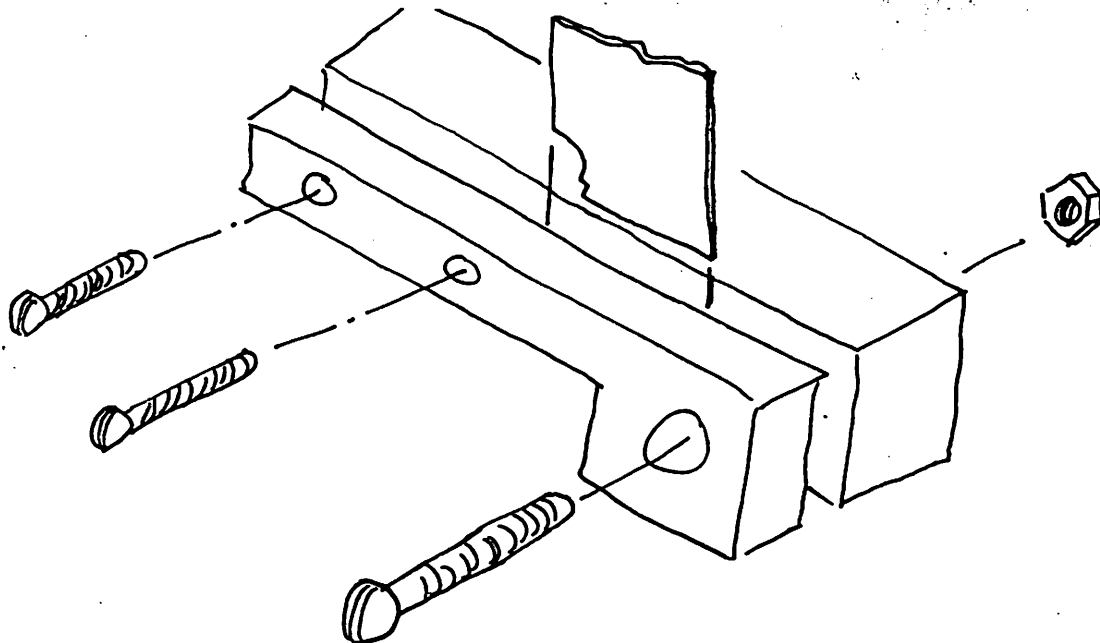
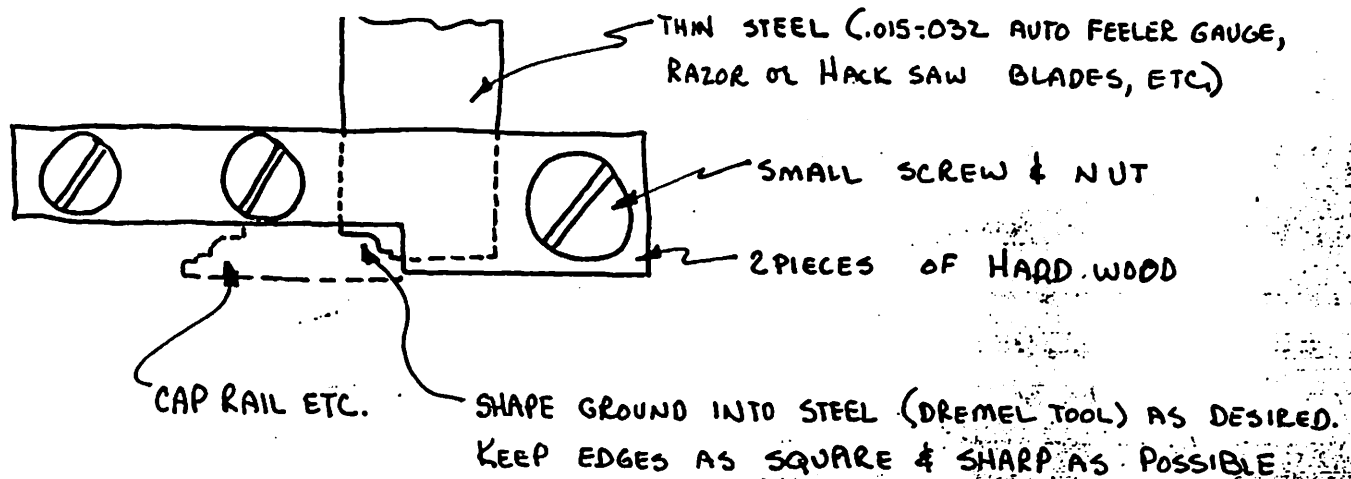

This device does not remove wood fast, but with some patience, and a sharp tool, it will do a very nice job. It works better in hard wood (box, pear, apple, maple, etc.) than it does in soft wood.

The other end of that piece of auto feeler gauge stock makes an excellent draw plate. Feeler gauge stock may be heat-treated by getting it red hot and quenching it in oil or water and soluble oil (soluble oil is auto radiator lubricant additive). In this state of heat treat it is very brittle so do not drop it. If you plan on heat-treating save the fine detail until after the heat treat, then grind it on as it has a tendency to burn away when red hot. Lots of luck, and let's see some fancy cap rails, head rails, and deck trim.

Reprinted from SMA Newsletter, June, 1977.