

FROM THE SHOP of BOB BEACH... an  
**ANTI-WARP DRYING JIG**

for hull frames made from  
 two thicknesses, glued with  
 overlapping crossgrains

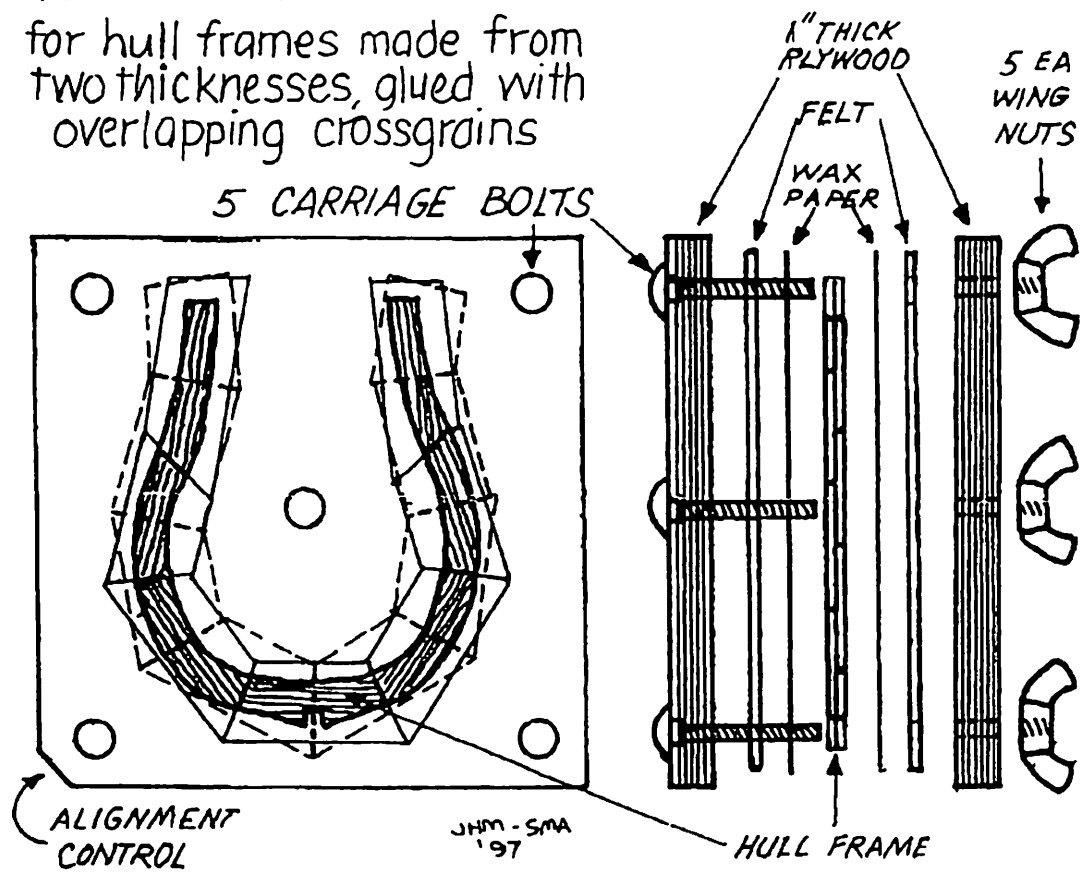

**Web Site is a Winner**

It will be no surprise to you that the Ship Modelers Association web site won first place for Community web sites at the Los Angeles County Fair. We owe this to Monica Chaban who created the site, and continues to be the web manager. Congratulations Monica, and thanks for your great work.

**Happenings At or Near the**

**December Meeting**

We will celebrate the holidays at the December meeting. We will have show and tell as usual, but we especially invite the ladies, and we will have special gifts for all of them who attend. For the rest of us, there will be free raffle tickets. Furthermore, the raffle items will be much better than usual. If you would like to bring a goodie to share, we will all help to eat or drink it. So we hope everyone will plan to attend. Do not fail to show this item to the lady in your life.

**Queen Mary**

CEO Robert Prevratel is seeking Long Beach City Council approval for a 5 million dollar loan to be used for continued refurbishment of the Queen Mary. I understand the bungee jump will be removed, and I say "Good riddance!" A plan is afoot to obtain the helicopter carrier New Orleans from the US Navy would be moored next to the Queen, to be used for a "Maritime Center for Excellence", with four museums, education programs, and an Ocean Camp similar to NASA's Space Camp